



sREH190x62-2cn

DIMENSION

SIZE : 190mmx70.0mm
 AIRFLOW : 228~401CFM
 WEIGHT : 1.4kg
 Noise : 48~68dBA
 IMPELLER : Plastic PA6.6(polyamide glass-fibre reinforced)
 Motor : Capacitor-Run Induction and external rotor Motor
 Rotor : Black paint
 Lead Wire : AWG#20 UL2450
 Insulation : Class B, Thermally protected
 Safety : UL.CUL.TUV.CE
 OPERATING TEMPERATURE : -10°C~+65°

Unit:mm(inch)

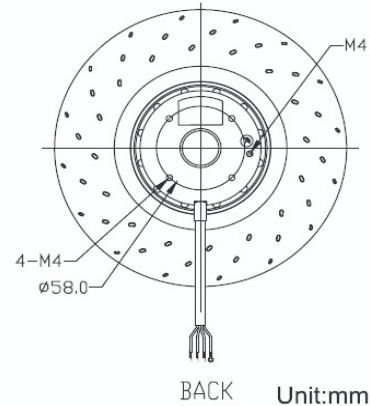
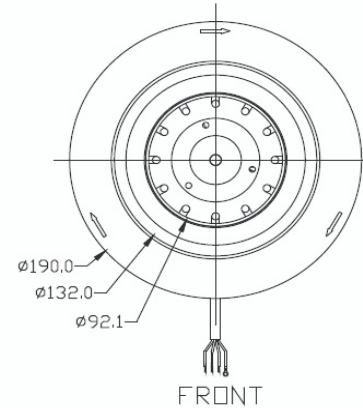
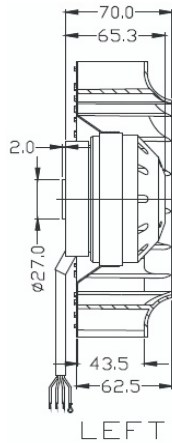

AIR PERFORMANCE

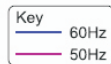
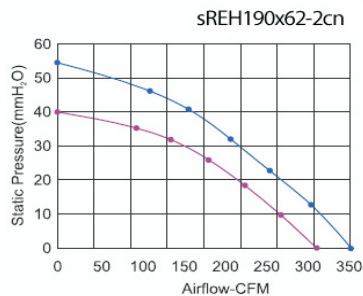

SPECIFICATION

MODEL NO.	RATED VOLTAGE (V)	FREQUENCY (Hz)	RATED CURRENT (A)	INPUT POWER (W)	SPEED (RPM)	AIR FLOW	NOISE dB(A) @ 1M
						CFM	
sREH190x62-2cn	115	60	1.04	122	2900	401	68