



D25089 Series

Ø254X89mm(Ø10" x3.5")

DIMENSION

HOUSING : Die – Cast Aluminum, Painted Black
 IMPELLER : Thermoplastic PBT, UL94V - 0
 BEARING : Ball
 INSULATION RESISTANCE : 10 meg Ohms Min.@500 VDC
 (Between Frame and Terminal)
 DIELECTRIC STRENGTH : 5 mA Max. at 500 VAC 60Hz for 1 minute
 (Between Frame and Terminal)
 WEIGHT : 1.8Kg
 ROHS COMPLIANCE : Yes

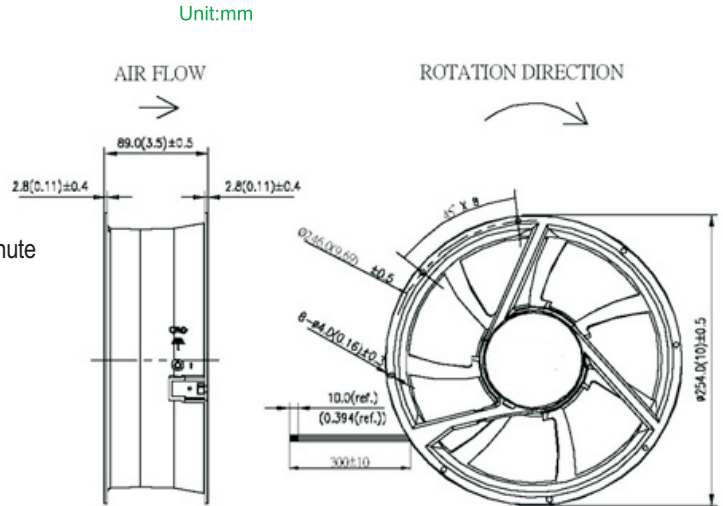

AIR PERFORMANCE

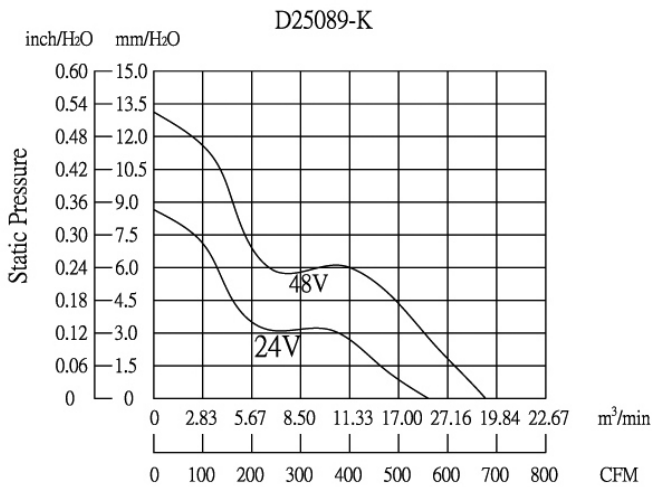

MOUNTION PANEL CUTOUT
 OUTLET SIDE & INLET SIDE

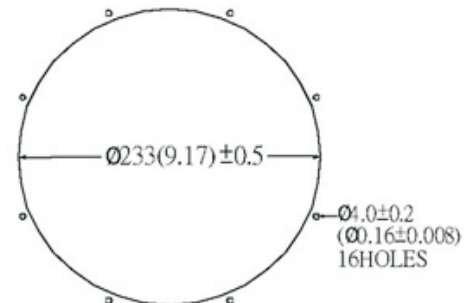

SPECIFICATION

MODEL NO.	RATED VOLTAGE (V)	RATED CURRENT (A)	INPUT POWER (W)	SPEED (RPM)	MAX. AIR PRESSURE		AIR FLOW		NOISE dB(A) @ 1M
					InchH ₂ O	mmH ₂ O	CFM	m ³ /min	
D25089V24H	24	1.2	28.8	1650	0.35	8.85	561	15.89	58
D25089V48H	48	1.2	57.6	1880	0.39	9.9	620	20.67	62