

# A15055 Series

Size: 150x172x55mm(5.9"x6.77"x2.17")

## DIMENSION

HOUSING : Die - Cast Aluminum, Painted Black  
 IMPELLER : Injection Molded of Flame Retardant Polycarbonate, Black  
 BEARING : Ball  
 MOTOR TYPE : AC Induction Capacitor Motor  
 INSULATION : Class A  
 OPERATING TEMPERATURE : -20°C to + 80°C  
 SAFETY : Thermally Protected (Auto Restart)  
 WEIGHT : 1 Kg (35 oz.)

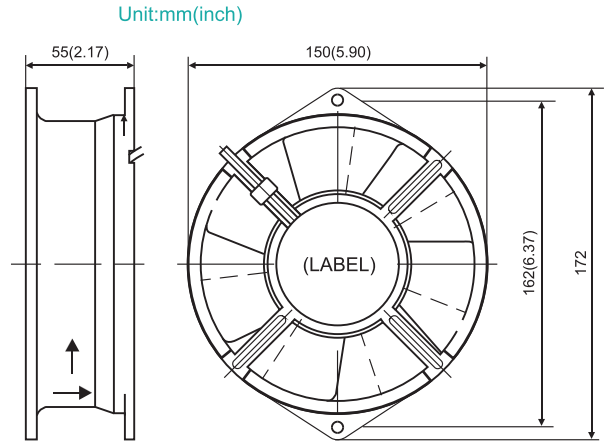

## AIR PERFORMANCE

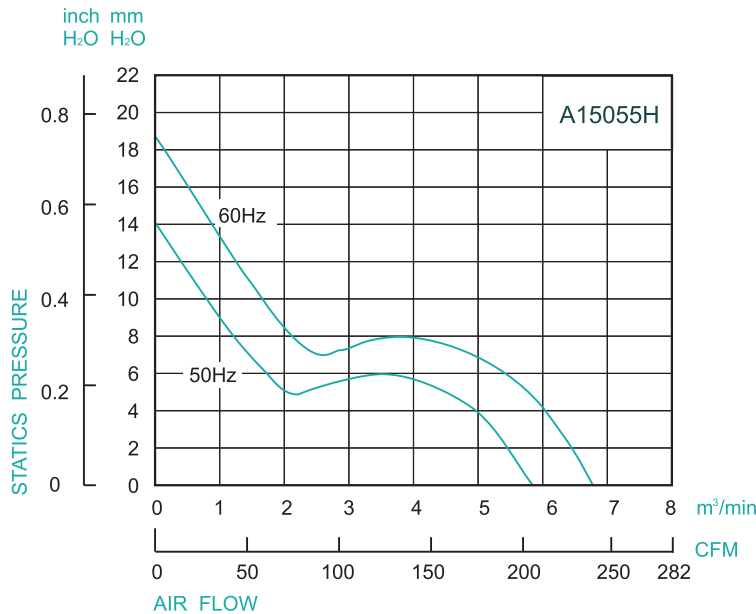

## SPECIFICATION

MODEL NO.	RATED VOLTAGE (V)	FREQUENCY (Hz)	RATED CURRENT (A)	INPUT POWER (W)	SPEED (RPM)	AIR FLOW		NOISE dB(A) @ 1M
						CFM	m <sup>3</sup> /min	
A15055V1H	115	50 / 60	0.32 / 0.43	39 / 51	2900 / 3300	205 / 245	5.80 / 6.90	50 / 53
A15055V2H	230	50 / 60	0.146 / 0.209	34 / 48	2900 / 3300	205 / 245	5.80 / 6.90	50 / 53